

Inertial Navigation System with MEMS-ESG and Automated Sun Altitude Measuring System using Web-Camera

*Gen Fukuda, Tokyo University of Marine Science and Technology.
Shogo Hayashi, Tokyo University of Marine Science and Technology*

BIOGRAPHY

Gen Fukuda received the Master degree from Tokyo University Marine Science and Technology in 2008. He is currently Doctoral student at same university. His research interests include the integration system with MEMS INS and celestial navigation system.

Shogo Hayashi received the B.E. degree from Tokyo University of Mercantile Marine in 1973. He received the Doctor of Engineering degree in Electronics and Marine from University of Tokyo in 1994. Since 1973 he has been engaged in Tokyo University of Marine Science and Technology where he is now professor. His major is navigation system and radar signal processing. During 1983-1990 he has researched on development of the Intelligent Ship Project. During 1987-1989 he was Captain of the university's training ship. He is an Executive Director of Japan Institute of Navigation, President of the Japanese Committee for Radio Aids to Navigation, Vice President of Japan Compass Adjusters' Association, and a member of Institute of Navigation(U.S.A.), IEEE.

ABSTRACT

In 2007, Micro Electro Mechanical Systems (MEMS) Electro-statically Gyro (ESG) was introduced by TOKYO KEIKI Co. Ltd Japan. The accuracy of this sensor has been dramatically improved compared with vibration types. For example, instability has been improved 10 times more than the vibration types. The MEMS-ESG could detect the relative angles as accurate as GPS compass in short term use. The Inertial Navigation System(INS) using this sensor was tested. It was examined whether it has enough accuracy as INS for use on a small ship. Since the MEMS INS has problem of errors increasing with time, normally a complementary system is used to reduce them. Since one of our objectives is to avoid using GPS, we consider other complementary system. A celestial navigation system is one of the possibilities for this purpose. Traditionally, the celestial navigation has been carried out by hand on the ships. However, the

system needs to be updated automatically to integrate a complementary system with MEMS INS. Therefore a Web camera with a CMOS(Complementary Oxide Silicon) sensor is used in this research. Although CMOS is not as accurate as CCD(Charge-coupled device), it has got many benefits, especially in cost, read-out speed and power consumption. Recently, the detection accuracy of CMOS sensor is much improved. In the past research, the sun movement was detected at an angular resolution of 5'14" per pixel and 2'16" per pixel for altitude and azimuth, respectively. However, CMOS cameras require much effort for calibrations. In addition to that, the increasing time with digital image processing is the problem for the update interval. Therefore a camera platform has been developed. It is able to turn the camera system towards the sun. Using the platform, it is able to reduce the use of pixels, because the camera is able to follow the sun movement. Then calibration would be much easier. The analysis shows that the detection accuracy and the speed of processing digital images are much improved compared with the camera without the platform.

INTRODUCTION

In small vessels, Gyro compass, magnet compass or GPS compass are used. GPS is also used for positioning.

Even though GPS is very accurate, small and inexpensive, it needs the signals from the satellite. Since GPS is worked by external signals from the satellite, several weak points have been discussed. Therefore in this research the autonomous system is considered.

The Inertial Navigation System is autonomous and overcomes the problems in GPS described above. In the recent technological advancements, most of the mechanical complexities of platform systems have been removed by fixing the sensors to the body of a host vehicle in modern inertial systems. It is called the strapdown inertial navigation system. But to maintain its accuracy, it still needs very accurate systems such as the ring laser gyro(RLG), the fiber optic gyro(FOG) or more accurate gyro such as the electrostatically

suspended gyroscope(ESG) and is also very complex systems. Those systems are unaffordable for the small vessels, but new type of MEMS sensors might be the solution for this problem.

In this research, the goal is to develop a small and cost effective autonomous system using MEMS sensors which is affordable for small vessels.

It is possible to know the true north and latitude by detecting the earth's turn rate. But it is not possible to get such information by using MEMS sensors at present. For example, to get the earth's rotation rate, they need to be ten times more accuracy than existing gyro sensors. For this reason, the research is started from developing the gyro compass using MEMS as accurate as gyro compass which is used in the ships.

MEMS-ESG Structure

The ESG was introduced during the 1950s in the United States. The ESG is very accurate and it has achieved drifts of the order of 0.0001[deg/h] and navigation accuracies of the order of 0.1 nautical miles per hour⁽⁶⁾. Unfortunately, despite being very simple concept, the design is complex and the gyroscope is large and expensive.

The MEMS-ESG was introduced by a Japanese company in July 2007. Although the accuracy is not the same as the previous ESG, its accuracy is greatly improved as MEMS gyro sensors. Additionally it is lower price than the previous ESG.

The MEMS-ESG is measuring the turn rate using the turning sensor rotor which is suspended by electrostatic power. When the turn rate is applied to the rotor, a slight tilt angle is occurring between sensor rotor and sensor case. A feedback torque is applied in order to return the rotor to the normal position. This feedback torque is proportional to turn rate, so the sensor can detect the turn rate. In addition, the sensor detects the three-dimensional accelerations by the torque which is applied for maintaining the sensor rotor in the center of the case.

The MEMS-ESG sensor structure has 3 layers that are glass, silicon and glass. The sensor structure is depicted schematically in Fig.1. The details of the sensor dimension are shown in Table1.

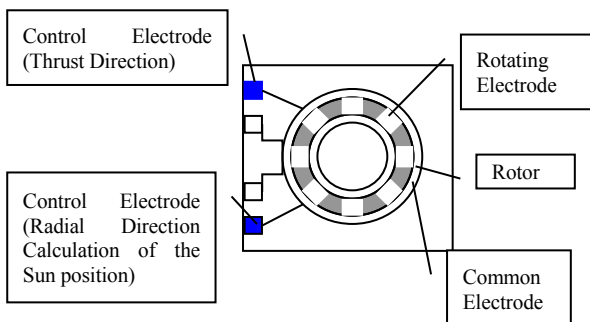

Fig 1 MEMS-ESG Sensor Structure

Table 1 The details of the sensor dimension

Rotor diameter	1.5[mm]
Thickness	50[μ m]
Top and bottom gap	3[μ m]
Radial dimension gap	2.5[μ m]

The Long Hours Data Analysis

For analyzing the MEMS-ESG, 85-hour data were collected with room temperature at the laboratory. Since the MEMS-ESG can only detect two axes rate, it needs two sensors for the INS. The outlook of the MEMS-ESG installed on the mount is shown in Fig. 2. Then sensor axes were arranged as in Fig.3 .

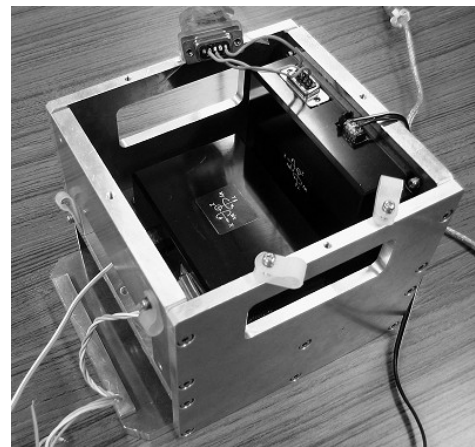

Fig 2 Sensors with mount

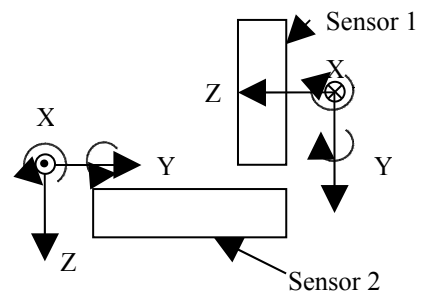

Fig 3 Sensor axes

In Fig.4 through Fig.9, the sensor outputs for each axis are shown. In addition, the sensor temperature data was shown in Fig.10. To see the X axis rate output in Fig.4, the data moved downward for the first 10 hours. This trend is also found in Fig.5 through Fig.7. Y and Z axes acceleration data moved upward for the first 10 hours. It is well known that, MEMS sensor output is hugely affected by the sensor temperature⁽¹⁾. Therefore the sensor temperature was measured and is shown in Fig.10. The sensor temperature was moving downward for first 10 hours. Therefore it is

considered that the MEMS-ESG sensor outputs were also affected by sensor temperature. This sensor temperature is mainly produced by FPGA in the sensor box. Then to reduce the sensor error, it needs some temperature stabilization. It is also observed that to see the Z axis acceleration output in Fig.9, the data is hugely moved for first 10-hour data compared with other two axes. Since upper and down side electrostatic powers are not stable compared with other two axes, the output moves as shown in Fig.9.

Considering these sensor output, MEMS-ESG needs some start up time before using it. In addition, the acceleration output of Z axis does not recommend using in INS.

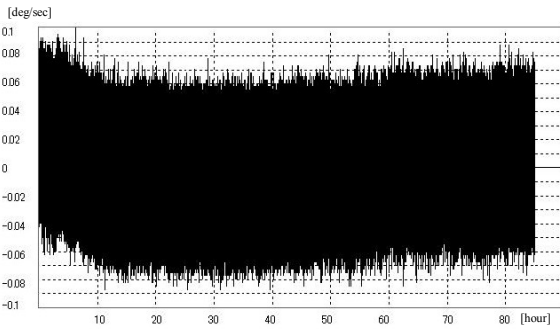

Fig 4 Sensor 2 X axis rate output

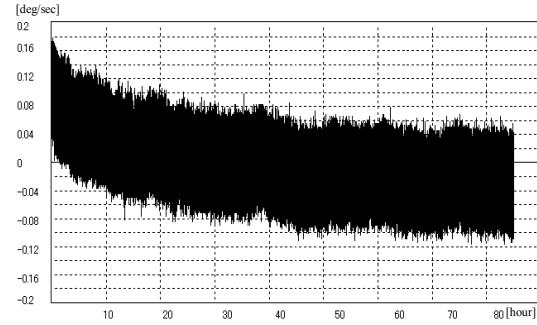

Fig 5 Sensor 1 Y rate output

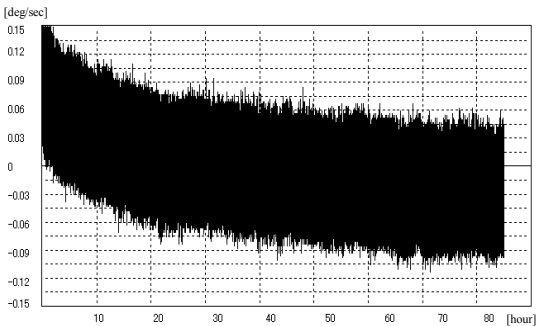

Fig 6 Sensor 2 Y axis rate output

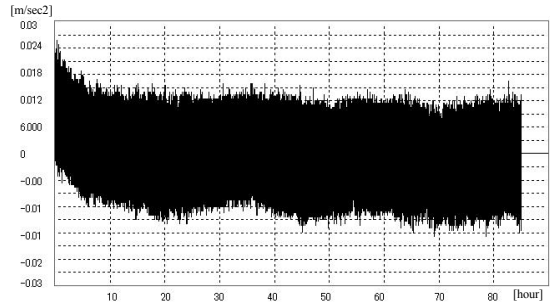

Fig 7 Sensor 2 X axis acceleration output

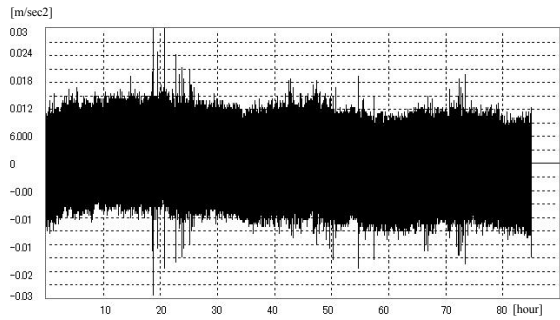

Fig 8 Sensor 2 Y axis acceleration output

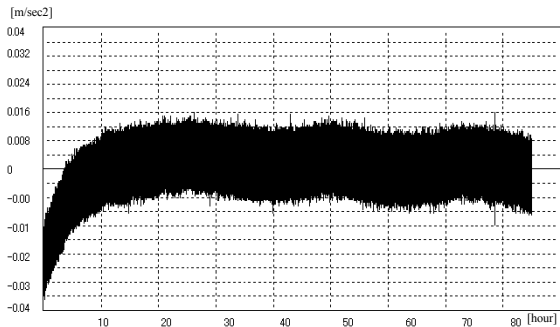

Fig 9 Sensor 2 acceleration output for Z axis

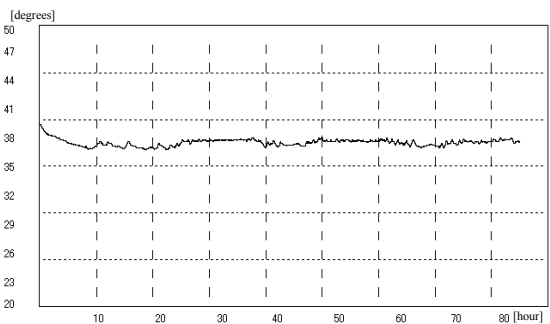

Fig 10 Sensor 2 Sensor temperature output

Allan Variance

Allan variance was developed by David W. Allan in 1966. The Allan variance of a time series of data is a

characterization of the noise and other processes in the data as a function of averaging time(2). Naser El-Sheimy(3) applied the Allan variance to vibration types MEMS sensors and studied sensor error terms. In this paper, the Allan variance is also applied to study MEMS-ESG.

The Allan variance of length T is defined as

$$\sigma^2(T) = \frac{1}{2(N-2n)} \sum_{k=1}^{N-2n} [\bar{\Omega}_{next}(T) - \bar{\Omega}_k(T)]^2 \quad (1)$$

where N is the total number of data points in the entire run, and n is the number of data points contained in the cluster and $\sigma(T)$ is the Allan variance. $\bar{\Omega}_k(T)$ is cluster average at time k.

$\bar{\Omega}_k(T)$ and $\bar{\Omega}_{next}(T)$ are following equations;

$$\bar{\Omega}_k(T) = \frac{1}{T} \int_{t_k}^{t_k+T} \Omega(t) dt \quad (2)$$

$$\bar{\Omega}_{next}(T) = \frac{1}{T} \int_{t_{k+1}}^{t_{k+1}+T} \Omega(t) dt \quad (3)$$

where $t_{k+1} = t_k + T$.

The Noise terms in Allan Variance

Specific noise terms are detected by using Allan variance. The sample plot is shown in Fig11 and Fig 12.

The followings are the integral solution for a number of specific noise terms. The details for the integral solution for a number of specific noise terms are given in the reference (5).

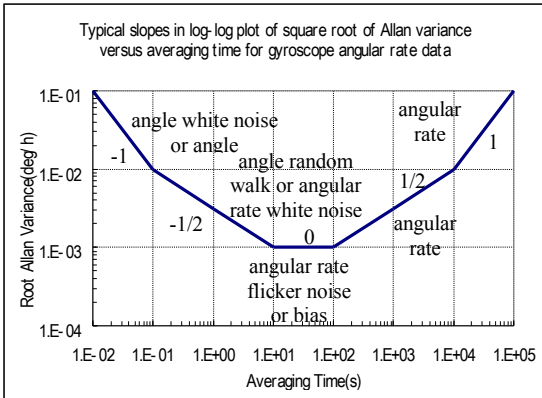

Fig 11 The sample plot of rate sensor noise terms in Allan Variance

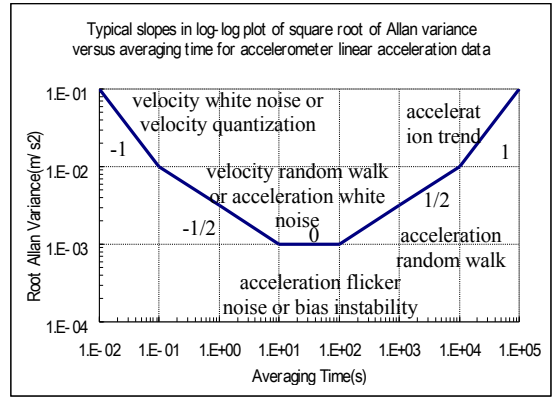

Fig 12 The sample plot of acceleration sensor noise terms in Allan Variance

Allan Variance Result

The Allan Variance calculation is done using 2-hour data in Fig.4 through Fig.8. The rate Allan variance and acceleration Allan variance results are shown in Fig13 and Fig.14 respectively.

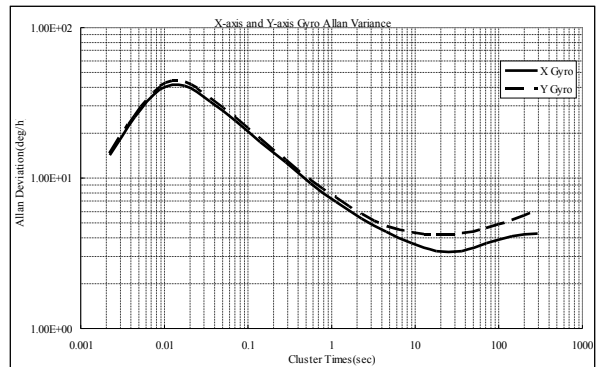

Fig 13 Rate output Allan Variance

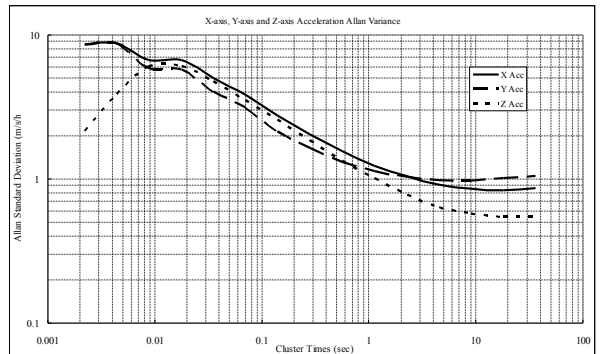

Fig 14 Acceleration Allan Variance Plot

Percentage error is calculated with following equation:

$$\sigma(\delta) = \frac{1}{\sqrt{2\left(\frac{N}{n} - 1\right)}} \quad (4)$$

where N is the total number of data points in the entire run, and n is the number of data points contained in the cluster.

The quantization noise was not observed with both rate output and acceleration output. Angular random walk is 0.1083 ± 0.0226 [deg/ \sqrt{h}] for X-axis and 0.1117 ± 0.0233 [deg/ \sqrt{h}] for Y-axis. X-axis and Y-axis bias instabilities are 3.2784 ± 0.0821 [deg/h] and 4.2461 ± 0.1063 [deg/h] respectively. All the data is shown in Table 2.

Acceleration is also studied and its calculated result is shown in Table 3.

Table 2 Rate Allan Variance Result

	Angular Random Walk [deg/ \sqrt{h}]	Bias Instability [deg/h]
X Gyro	0.1083 ± 0.0226	3.2784 ± 0.0821
Y Gyro	0.1117 ± 0.0233	4.2461 ± 0.1063

Table 3 Acceleration Allan Variance Result

	Acceleration Random Walk [m/s/ \sqrt{h}]	Bias Instability [m/s/h]
X Acc.	0.0175 ± 0.0037	0.8339 ± 0.0209
Y Acc.	0.0133 ± 0.0028	0.9651 ± 0.0241
Z Acc.	0.0159 ± 0.0033	0.5443 ± 0.0136

The Sun Altitude Detecting System

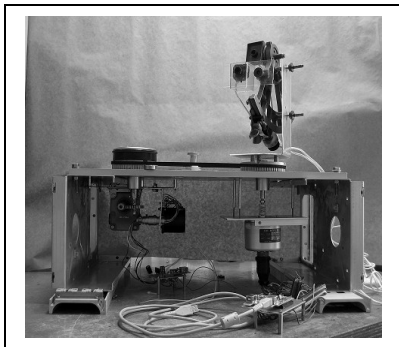

Fig 15 The picture of sun altitude detecting system

MEMS-ESG are not able to detect the absolute angles, because the earth's turn rate is covered with white noise. Also when the MEMS is used for INS, the errors increasing with time are the most problem. To compensate them, the GPS is widely used as complement system. However the GPS is not in our objective, then the sun altitude detecting system was considered. In the past research, using 350×288 resolution camera, the sun movement was detected at an angular resolution of $5'14''$ per pixels and $2'16''$ per pixels for the altitude and direction respectively. For the complement system, more resolution is demanded to detect the position.

The New Sun Altitude Detecting System

One of the solutions to increase the resolution is use higher pixel cameras. Therefore, the new system is equipped with 1200×1600 CMOS camera. However the data transmit time also increases. For example, using old system, the update time increases at 20[s]. To solve this problem, the new system is able to turn by step motor. Since the camera is able to turn to the sun, the system does not need to scan whole CMOS sensor areas. The calibration time also decreases for this reason.

Test Result

Two days test were carried out. Both tests were held in Tokyo University of Marine Science and Technology. The first and second test results were shown in Fig.16 and Fig.18 respectively. In the first test, the CMOS scan area was set 30×1200 pixel, whereas 10×1200 pixel in the second date test.

The average resolution of 0.019055 [deg] and 0.022405414 [deg] are achieved for the first test and the second test respectively. The resolution increased 4.6 times for the first test and 3.9 times for the second test compared with the previous system. Although the camera pixels are increased, average update time was achieved for 2[s].

In Fig.16 and Fig.18, it can be observed some data are moving like stares (e.g. circled point A in Fig.16). Since the camera could not follow the sun movement, the data is missing during that time. Comparing Fig.16 and Fig 18, although the resolution decreases in the second test, the data movement is more stable in Fig. 18. For this reason, it is better to use less CMOS scan areas. However, when it is used on the ship, there are roll, yaw and pitch. If the camera system is moving more, it is needed more pixel in a horizontal direction to capture the sun image.

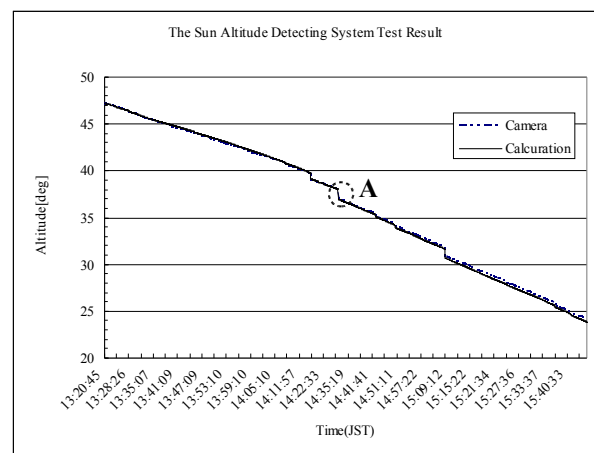

Fig 16 The first Sun Altitude Detecting System Test

Result

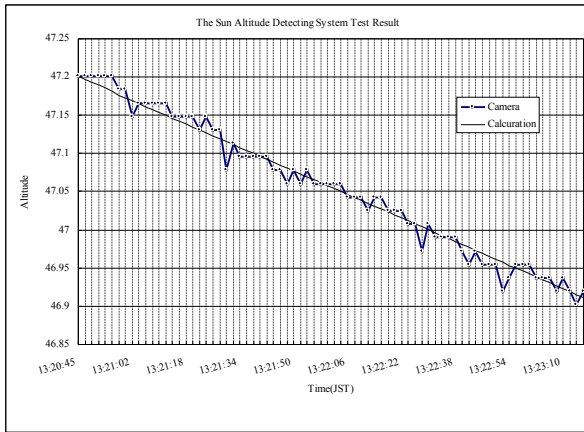

Fig 17 2 minuts data of Fig16

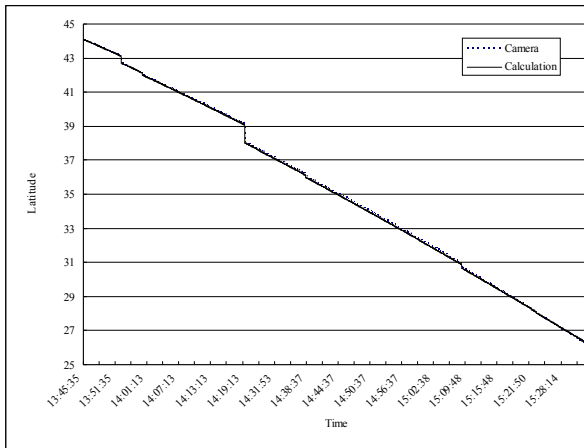

Fig 18 The second Sun altitude detecting System Test Result

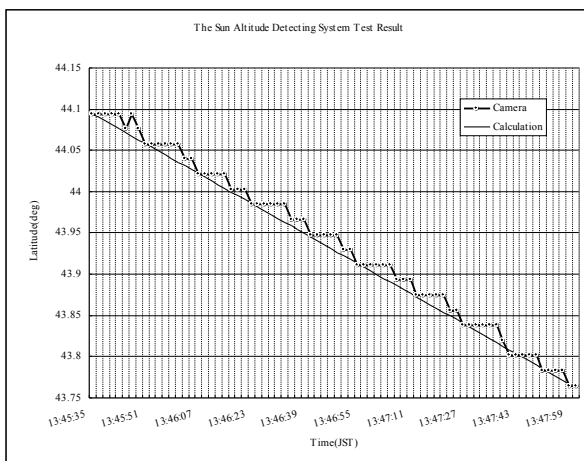

Fig 19 2 minuts data of Fig18

Conclusion

In the past research, because MEMS sensor accuracy is not good enough for long hour use, MEMS sensors were only studied for short term use. The MEMS-ESG has increased its accuracy compared with vibration types. In addition, considering the MEMS-ESG structure, the MEMS-ESG has got much potential to increase its accuracy in the near future. Therefore, these sensors might be used in long term navigation in the future. For this reason, the long term sensor trend was studied in this paper. The 85-hour data was collected in a laboratory at room temperature. Not only the vibration types MEMS, but also the MEMS-ESG outputs were affected by the sensor temperature. For the first 10 hours, rate and acceleration outputs for each axis were continuously moving one direction. The sensor temperature graph shows that the temperature output also decreased for first 10 hours. Therefore, it is considered that the sensor temperature affected the sensor output. The following terms would be needed to reduce temperature affect:

- Equipment to stabilize the sensor temperature
- Temperature calibration
- Some starting-up time to stabilize sensor temperature

It was also found that the acceleration output for Z axis largely moved for first 10 hours compared with other two axes. The sensor structure was considered to affect the Z axis output in addition to the sensor temperature. Therefore, it is recommended not to use Z axis acceleration output with INS.

The Allan Variance allows a systematic characterization of the various random errors contained in the output data. For the MEMS-ESG, the quantization noise is not observed for both gyros and acceleration sensors. In the short and long cluster times, the angular random walk and the acceleration random walk are the dominant errors for gyro sensor and acceleration sensor respectively. Also bias instability terms are the dominant error in the long cluster times for both sensors.

With new sun altitude detecting system, the average update time of 2[s] was achieved. The average resolution of 0.019055[deg] for the first test and -0.022405414[deg] for the second test were achieved. This is 4.6 times more resolutions compared with previous system. Although the resolution is decrease in the second test, the data movement is more stable. For this reason, it is better to use less CMOS can areas.

Reference

- (1) Aggarwal, P., Syed, Z., Niu, X. and El-Sheimy(2008): A Standard Testing and Calibration Procedure for Low Cost MEMS Inertial Sensors and Units, The Journal of Navigation, The Royal Institute of Navigation, pp. 323-336
- (2) The Gyro and Accelerometer Panel of the IEEE

Aerospace and Electronics Systems

Society(2005): Draft recommended practice for inertial sensor test equipment, instrumentation, data Acquisition, and analysis, IEEE Standards Activities Department Standards Licensing and Contracts, pp91

- (3) Naser El-Shimy and Haiying Hou and Xiaoji Niu (2008): Analysis and Modeling of Inertial Sensors Using Allan Variance, IEEE Transactions on Instrumentation and Measurement, VOL.57, NO. 1,pp140-149
- (4) IEEE Draft Standard Specification Format Guide and Test Procedure for Single-Axis Laser Gyros, IEEE P647_D06, 2005
- (5) Gen Fukuda and Shogo Hayashi(2009): The Basic Research for the New Compass System Using Latest MEMS, TRANS NAV 2009
- (6) David Titterton & John Weston(2004): Strapdown Inertial Navigation Technology, 2nd Edition, IEE Radar, Sonar and Navigation series17